

### Three Phase Squirrel Cage Induction Motor



Motor Type: TA3-90S-4 B5

#### Electrical Data

RATED VALUES						STARTING VALUES				BREAKDOWN	EFFICIENCY			EFFICIENCY CLASS				
VOLTAGE	POWER		SPEED	CURRENT	TORQUE	Cos φ	CURRENT		TORQUE		TORQUE	%			IEC 60034-30-1			
V	kW	Hz	rpm	A	Nm	4/4	I <sub>A</sub> / I <sub>N</sub>	Y	D	M <sub>A</sub> / M <sub>N</sub>	Y	D	Mk/ Mn	Nm	4/4	3/4	2/4	IE
230/400	1,1	50	1433	4,3/2,5	7,33	0,77	6,9			2,9			3,6		IE3-84,1	83,8	82,3	IE3
265/460	1,1	60	1745	3,8/2,2	6,02	0,73	6,7			2,8			3,5		IE3-86,5	86,2	84,6	IE3

#### Mechanical Data

Bearing DE	6205-ZZ	Color	RAL 7030
Bearing NDE	6205-ZZ	Motor protection	PTC
Lubricants	Shell Gadus S2 V100Q.2	Method of cooling	IC 411
Condensation drain hole	No	Terminal box position	Top
External earthing terminal	Yes	Material of terminal box	Aluminium
Vibration class	A	Terminal plate thread	M4
Insulation class	F	Cable gland	1xM25
Duty type	S1	Clamping range	13-18 mm
Direction of rotation	Clockwise	Mounting type	IM 3001 (B5)
Housing material	Aluminium		
Type of balancing	Half Key		

#### Environmental Data

#### Others

Ambient temperature	-20 / +40 °C	Type of protection	IP 55
Altitude above sea level	1000 m	Sound pressure level	45,3 dBA
		Moment of inertia (kg.mm <sup>2</sup> )	2082,08
		Standard	IEC 60034-1
		Weight (kg)	12,6

#### Dimensions

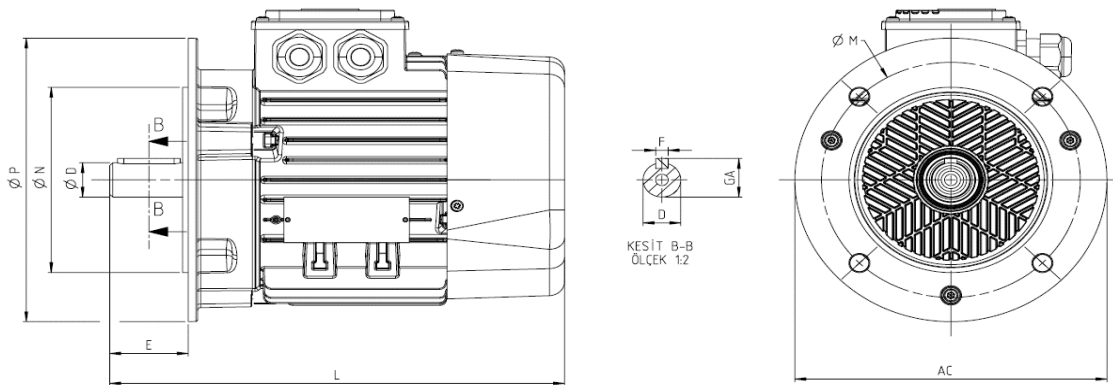

Main Dimensions		Foot Mounted Motors						Shaft				Flange Mounted Motors			
AC	L	B	A	H	HD	K	C	D	E	GA	F	P	N	M	R
198.9	290	-	-	-	-	-	-	24	50	27	8	198.9	130	165	-